

GENERAL NOTES - STRUCTURAL

- The contractor shall verify dimensions and conditions before construction and notify the engineer of any discrepancies, inconsistencies, or difficulties affecting the work before proceeding.
- The contractor shall coordinate all disciplines, verifying size and location of all openings, whether shown on structural drawings or not, as called for on architectural, mechanical, or electrical drawings. All conflicts, inconsistencies, or other difficulties affecting structural work shall be called to the architect or engineer's attention for direction before proceeding.
- All design and construction work for this project shall conform to the requirements of the 2006 International Building Code, as amended by the City of Kansas City, Missouri. These drawings are for this specific project and no other use is authorized.
- Concrete:
  - All concrete except exterior flat work shall develop minimum ultimate compressive design strength of 3500 psi in 28 days, but not less than 500 pounds of cement shall be used per cubic yard of concrete regardless of strengths obtained, not over 6 gallons of water per 100 pounds of cement and not over 4 inches of slump.
  - Concrete for exterior flatwork shall have a minimum design compressive strength of 4500 psi in 28 days, with not less than 560 pounds of cement per cubic yard of concrete, not over 5 gallons of water per 100 pounds of cement, with 6% +/- 1% air entrainment, and a maximum of 4 inches of slump.
  - The preceding minimum mix requirements may have water-reducing admixtures conforming to ASTM C494 added to the mix at manufacturer's dosage rates for improved workability.
  - The preceding minimum mix requirements may have up to 15% maximum of the cement content replaced with an approved ASTM C618 Class C Fly ash, provided the total minimum cementitious content is not reduced.
  - Aggregate for all concrete shall be well graded from coarsest to finest with no more than 10 percent and not less than 0 percent retained on an individual sieve, except that less than 0 percent may be retained on coarsest sieve and on No. 50 and finer sieves.
  - All interior concrete slabs on grade shall be placed over 15 mil, Class A Vapor Barrier per ASTM E1745 with less than 0.01 perms, tested after mandatory conditioning. All joints shall be lapped and sealed per manufacturer's recommendations. All penetrations, as well as damaged vapor barrier material shall also be sealed per manufacturer's recommendation prior to concrete placement. The vapor barrier shall be placed over free-draining granular material as prescribed by the project soils report.
  - All concrete is reinforced concrete unless specifically called out as unreinforced. Reinforce all concrete not otherwise shown with same steel as in similar sections or areas. Any details not shown shall be detailed per ACI 315 and meet requirements of ACI 318, current editions.
  - Control joints in dirt formed slab to be as shown on plans. Where not shown, limit controlled areas to not more than 150 square feet, or 12 feet on any side.
  - Contractor shall verify that all concrete inserts, reinforcing and embedded items are correctly located and rigidly secured prior to concrete placement.
  - Construction joints in beams, slabs, and grade beams shall occur at midspan (middle third) unless noted otherwise. Provide 2 x 4 horizontal keys at construction joints for shear transfer.
  - No aluminum items shall be embedded in any concrete.

- All reinforcing steel shall conform to the requirements of ASTM A615 or A706 grade 60 steel. Welded plain wire fabric shall be supplied in sheets and conform to the requirements of ASTM A185.
- Clear minimum coverage of concrete over reinforcing steel shall be as follows:
 

Concrete placed against earth	3"
Formed concrete against earth	2"
Slabs	1"
Beams or Columns	1-1/2"
Other	2"
- All coverage shall be nominal bar diameter minimum.
- All dowels shall be the same size and spacing as adjoining main bars (splice lap 40 bar diameters or 24" minimum unless noted otherwise).
- At corners of all walls, beams, and grade beams supply corner bars (minimum 2'-0" in each direction or 40 bar diameters) in outside face of wall, matching size and spacing of horizontal bars. Where there are no vertical bars in outside face of wall, supply 3 - #4 vertical support bars for corner bars.
- Bars marked continuous and all vertical steel shall be lapped 40 bar diameters (2'-0" minimum) at splices and embedments, unless shown otherwise. Splice top bars near midspan and splice bottom bars over supports, unless noted otherwise.
- At all holes in concrete walls and slabs, add 2 - #5 bars (opening dimension plus 30 diameters long) at each of four sides and add 2 - #5 x 5'-0" diagonally at each of four corners of hole. Openings in 8" thick walls are reinforced similar, but with 1 - #5 instead of 2 - #5, respectively.
- Accessories shall be as specified in latest edition of the ACI Detailing Handbook and the concrete Reinforcing Steel Institute Design Handbook. Maximum accessory spacing shall be 4'-0" on center, and all accessories on exposed surfaces are to have plastic coated feet.
- All slabs and stairs not shown otherwise shall be 6" thick with #4 bars at 12" on center each way. All exterior porches and stoops not otherwise detailed may be constructed in any standard manner, solid or hollow, but must be reinforced with #4 bars at 12" on center each way minimum. Porches shall be doveled to adjacent walls or grade beams with #4 bars at 12" on center, hooked or embedded 40 diameters into both members. Slope porches 1/8" per foot for drainage unless noted otherwise.

- All structural steel beams and columns shall be ASTM A992, grade 50 steel and all miscellaneous steel shall be ASTM A36 grade steel. Hollow Structural Sections (HSS) shall be ASTM A500, grade B. Fabrication and erection shall be in accordance with AISC 303-05 @Code of Standard Practice for Steel Buildings and Bridges in the 13th Edition of the AISC Steel Construction Manual.

- Concrete Block Masonry:
  - Concrete block used in exterior walls or load bearing walls shall meet the requirements of ASTM C90 and have a minimum net compressive strength of 1900 psi and laid up using type N mortar such that Fm equals 1850 psi. Any block in contact with earth shall be normal weight units, laid using type 'S' mortar and grouted solid.
  - The contractor shall provide adequate temporary bracing for all masonry walls during construction.
  - All concrete block shall have 9 gage (or larger) horizontal joint reinforcing (ladder or truss) per architectural drawings and specifications (16" maximum vertical spacing).
  - Cavity wall construction shall be reinforced as designed for specific concrete block used. The horizontal joint reinforcing shall be of the ladder or truss style per specification and continuous between brick and block, as prescribed by architectural drawings.
  - Concrete block shall be reinforced as follows:
    - Vertical reinforcing shall be a minimum of 1 - #4 bar in 8" walls at 32" on center, at each corner, at each door and window jamb, each side of control joints and in the end void of each length of wall. Lap splices for masonry vertical reinforcing shall be 40 bar diameters or 24" minimum.
    - Horizontal reinforcing:
      - Horizontal joint reinforcing as noted above.
      - Continuous horizontal bars shall be included per section or detail in bond beam or optional running bond beam where noted. Where bond beams are continuous at corners of walls, supply corner bars matching size of horizontal bars (minimum 2'-0" or 40 bar diameters in each direction).
  - Grout, where noted above, shall have a minimum design ultimate compressive strength of 2500 psi at 28 day test and 3/8" maximum aggregate size.
  - Non-load bearing concrete block walls shall be isolated from adjacent structural elements with vertical 3/8" control joints and at the top of the wall with 1" air space or compressible material and support per architectural detail.
  - Unless otherwise covered on architectural plans or specifications, vertical control joints in masonry construction shall be 3/8" wide, full height of wall. Joints shall be spaced at a maximum of 24'-0" on center and coordinated with the architect. All horizontal joint reinforcing shall be discontinuous at control joints in masonry. All bond beam horizontal reinforcing shall be continuous through control joints.

- Lintels over all openings in walls not otherwise covered shall be one 5" x 3-1/2" x 5/16" angle for each 4' of masonry. All exterior lintels to be galvanized.
- Walls shall be anchored top and bottom by dowels matching wall vertical reinforcing (unless noted otherwise) from floor slab bottom and bracing angles at the top per details on the drawings.

- Shop Drawing Review:
  - Bob D. Campbell and Company, Inc. will review the General Contractor's (GC) shop drawings and related submittals (as indicated below) with respect to the ability of the detailed work, when complete, to be a properly functioning integral element of the overall structural system designed by Bob D. Campbell and Company, Inc.
  - Prior to submittal of a shop drawing or any related material to Bob D. Campbell and Company, Inc., the GC shall:
    - Review each submission for conformance with the means, methods, techniques, sequences and operations of construction and safety precautions and programs incidental thereto, all of which are the sole responsibility of the GC.
    - Review and approve each submission.
    - Stamp each submission as approved.
  - Bob D. Campbell and Company, Inc. shall assume that no submission comprises a variation unless the GC advises Bob

- Concrete mix designs and material certificates including admixtures and compounds applied to the concrete after placement.
- Reinforcing steel shop drawings including erection drawings and bending details. Bar list will not be reviewed for correct quantities.
- Elevations of all reinforced concrete masonry walls at a scale no smaller than 3/8" = 1'-0" showing all required reinforcing.
- Grout mix designs (for CMU).
- Construction and control joint plans and/or elevations.
- Structural steel connection design drawings and piece details. Include joist, framing and connector submittals. Include miscellaneous decking specified on the structural drawings, but do not submit framing specified on non-structural drawings for Bob D. Campbell and Company, Inc. review.
- Structural steel connection design calculations.
- Miscellaneous anchors shown on the structural drawings.

- Bob D. Campbell and Company, Inc. shall review shop drawings and related materials with comments provided that each submission has met the above requirements. Bob D. Campbell and Company, Inc. shall return without comment unrequired material or submissions without GC approval stamp.

- Shop drawings and related material (if any) required are indicated below. Should Bob D. Campbell and Company, Inc. require more than ten (10) working days to perform the review, Bob D. Campbell and Company, Inc. shall so notify the GC.

- Structural Special Inspection:
  - The structural design for this project is based on completion of special inspections during construction in accordance with section 1704 of the 2006 International Building Code. The owner shall employ one or more qualified special inspectors to provide the required special inspections.
  - Special Inspections shall be required for the items indicated below. The General Contractor shall provide notification to the inspector when items requiring inspection are ready to be inspected and provide access for those inspections.
    - Placement of Concrete
    - Testing of Concrete
    - Bolts in Concrete
    - Placement of Reinforcing Steel
    - Verification of Soil Bearing Capacities
    - High Strength Bolting
    - Post-Installed Anchors
    - Structural Welding
    - Structural Masonry (Level I)
  - The special inspector shall furnish inspection reports to the building official, owner, architect and structural engineer, and any other designated person.
  - All discrepancies shall be brought to the immediate attention of the contractor for correction, then, if uncorrected, to the proper design authority, building official and structural engineer.
  - The special inspector shall submit a final signed report stating that the work requiring special inspection was, to the best of the inspector's knowledge, in conformance with the approved plans and specifications and the applicable workmanship provisions of the building code.

- Copyright and Disclaimer:
  - All drawings in the structural set (5-series drawings) are the copyrighted work of Bob D. Campbell and Company, Inc. These drawings may not be photographed, traced, or copies in any manner without the written permission of Bob D. Campbell and Company, Inc. Exception: Original drawings may be printed for distribution to the owner, architect, and general contractor for coordination, bidding, and construction. Subcontractors may not reproduce these drawings for any purpose or in any manner.
  - Richard C. Crabtree, P.E., registered engineer and a representative of Bob D. Campbell and Company, Inc., do hereby accept professional responsibility as required by the professional registration laws of this state for the structural design drawings consisting of 5-series drawings. I hereby disclaim responsibility for all other drawings in the construction document package, they being the responsibility of other design professionals whose seals and signed statements may appear elsewhere in the construction document package.

- Richard C. Crabtree, P.E.

- Bob D. Campbell and Company, Inc. will review the General Contractor's (GC) shop drawings and related submittals (as indicated below) with respect to the ability of the detailed work, when complete, to be a properly functioning integral element of the overall structural system designed by Bob D. Campbell and Company, Inc.

- Prior to submittal of a shop drawing or any related material to Bob D. Campbell and Company, Inc., the GC shall:
  - Review each submission for conformance with the means, methods, techniques, sequences and operations of construction and safety precautions and programs incidental thereto, all of which are the sole responsibility of the GC.
  - Review and approve each submission.
  - Stamp each submission as approved.
- Bob D. Campbell and Company, Inc. shall assume that no submission comprises a variation unless the GC advises Bob

- Bob D. Campbell and Company, Inc. shall assume that no submission comprises a variation unless the GC advises Bob

- Bob D. Campbell and Company, Inc. shall assume that no submission comprises a variation unless the GC advises Bob

- Bob D. Campbell and Company, Inc. shall assume that no submission comprises a variation unless the GC advises Bob

- Bob D. Campbell and Company, Inc. shall assume that no submission comprises a variation unless the GC advises Bob

- Bob D. Campbell and Company, Inc. shall assume that no submission comprises a variation unless the GC advises Bob

- Bob D. Campbell and Company, Inc. shall assume that no submission comprises a variation unless the GC advises Bob

- Bob D. Campbell and Company, Inc. shall assume that no submission comprises a variation unless the GC advises Bob

- Bob D. Campbell and Company, Inc. shall assume that no submission comprises a variation unless the GC advises Bob

- Bob D. Campbell and Company, Inc. shall assume that no submission comprises a variation unless the GC advises Bob

- Bob D. Campbell and Company, Inc. shall assume that no submission comprises a variation unless the GC advises Bob

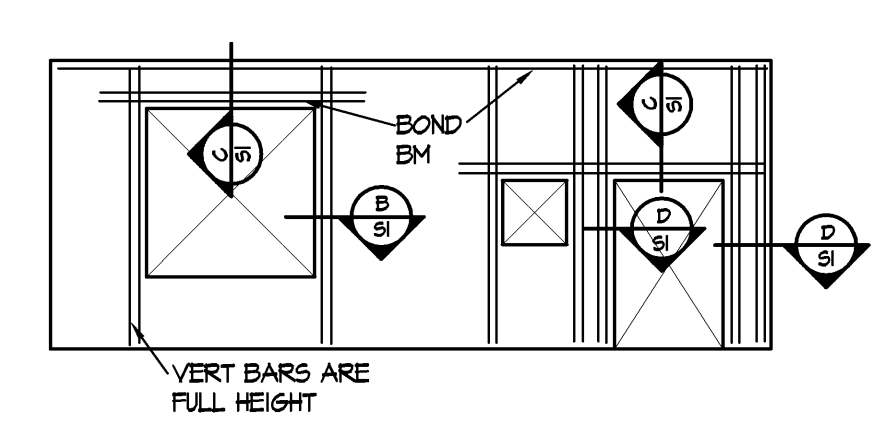

TYPICAL OPENING REINFORCEMENT  
1.) 1-#4 VERT BAR IN 8" CMU WALLS FOR EACH LINE SHOWN ON ELEVATION.

- VERTICAL REINFORCING BARS SHOWN SEPARATE ON "TYPICAL OPENING" SHALL BE PLACED IN SEPARATE VOIDS.
- VERTICAL REINF. BARS SHALL BE DOVELED TO FOUNDATION WITH A DOVEL OF MATCHING SIZE AND SPACING.
- 2#4 HORIZ. BARS FOR EACH LINE SHOWN ON ELEVATION.
- CONTRACTOR SHALL COORDINATE AND VERIFY OPENINGS IN MASONRY WALLS. OPENINGS SHALL BE DETAILED ON REINFORCING SHOP DRAWINGS ELEVATIONS.
- LINTEL REINFORCING (G/SI):
  - OPENINGS 4'-0" OR LESS WIDE - (2) #4 CONT.
  - OPENINGS BTWN 4'-0" & 6'-0" WIDE - (2) #5 CONT.
  - OPENINGS BTWN 6'-0" & 8'-0" WIDE - (2) #6 CONT.
  - OPENINGS BTWN 8'-0" & 12'-0" WIDE - (2) #6 CONT.

TYPICAL OPENING & COLUMN REINF.  
CMU WALL ELEVATION (A) NO SCALE

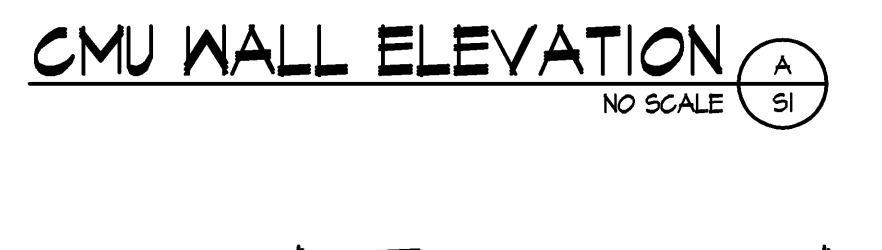

- REBAR POSITIONER OR SUPPORT @ 48" o.c.
- TOP REINF PER LINTEL NOTE #6 OF A/SI
- BOT REINF PER LINTEL NOTE #6 OF A/SI
- REINFORCING CHAIR SUPPORT @ 48" o.c.
- REBAR POSITIONER OR SUPPORT @ 48" o.c.
- TOP REINF PER LINTEL NOTE #4 OF A/SI
- BOT REINF PER LINTEL NOTE #6 OF A/SI
- REINFORCING CHAIR SUPPORT @ 48" o.c.
- REBAR POSITIONER OR SUPPORT @ 48" o.c.
- TOP REINF PER LINTEL NOTE #6 OF A/SI
- BOT REINF PER LINTEL NOTE #6 OF A/SI
- REINFORCING CHAIR SUPPORT @ 48" o.c.

TYP. LINTELS AT ALL CMU WALLS  
SECTION (C) 1/2" = 1'-0"

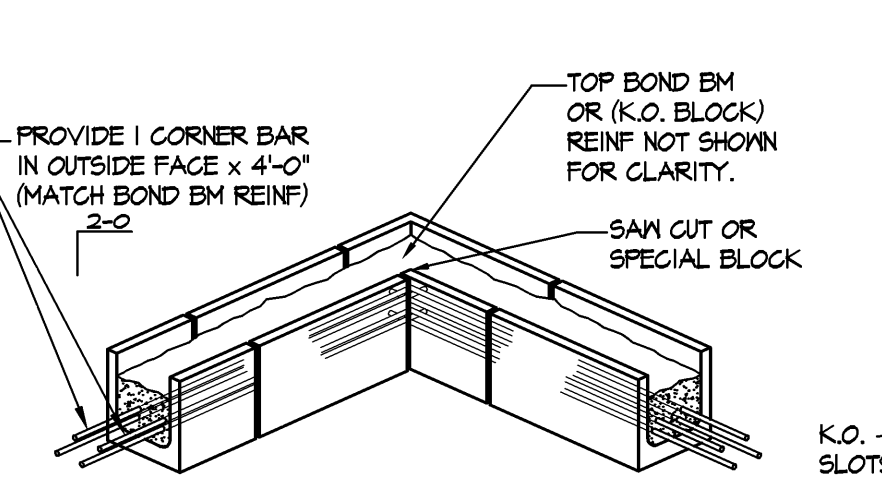

DETAIL (D) 3/4" = 1'-0"  
"KNOCKOUT" or TROUGH BOND BM BLOCK (TYPICAL UNIT EXCEPT AT ALL OPENINGS) SOLID BOT. BM. BM SHALL BE USED. PROVIDE GROUT STOP (RE.SPEC.) UNDER K.O. BOND BEAMS OVER CELLS WHICH ARE NOT TO BE REINFORCED AND GROUTED.



SECTION (B) 1/2" = 1'-0"

- VERTICAL REINF. PLACEMENT TOLERANCE SHALL BE 3/4" FROM LOCATIONS NOTED.
- MORTAR CMU WEBS ADJACENT TO GROUTED VOIDS. (TYP.)
- ALL MORTAR PROJECTIONS INTO GROUTED VOIDS SHALL BE LESS THAN 1/2" BEYOND INSIDE FACE OF MSRY.
- REBAR POSITIONERS SHALL BE PROVIDED TO SUPPORT BOTH ENDS OF EACH BAR AND AT A MAXIMUM OF 32" o.c. POSITIONER SHALL BE 1 GA. WIRE (MIN.) & HOT DIP GALVANIZED. LAPPING BAR LOCATION FOR NEXT LIFT (TYP.) SINGLE BAR REINF.

SECTION (B) 1/2" = 1'-0"

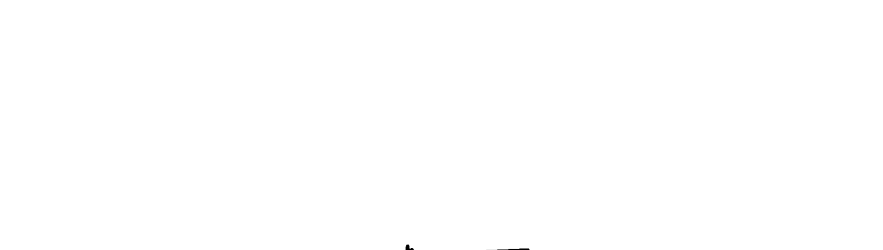

- REBAR POSITIONER OR SUPPORT @ 48" o.c.
- TOP REINF PER LINTEL NOTE #6 OF A/SI
- BOT REINF PER LINTEL NOTE #6 OF A/SI
- REINFORCING CHAIR SUPPORT @ 48" o.c.
- REBAR POSITIONER OR SUPPORT @ 48" o.c.
- TOP REINF PER LINTEL NOTE #4 OF A/SI
- BOT REINF PER LINTEL NOTE #6 OF A/SI
- REINFORCING CHAIR SUPPORT @ 48" o.c.
- REBAR POSITIONER OR SUPPORT @ 48" o.c.
- TOP REINF PER LINTEL NOTE #6 OF A/SI
- BOT REINF PER LINTEL NOTE #6 OF A/SI
- REINFORCING CHAIR SUPPORT @ 48" o.c.

TYP. LINTELS AT ALL CMU WALLS  
SECTION (C) 1/2" = 1'-0"

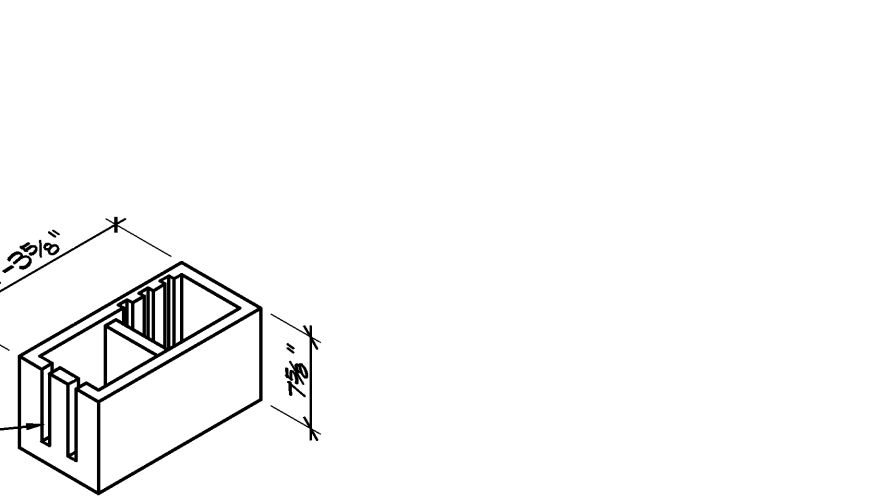

DETAIL (D) 3/4" = 1'-0"  
"KNOCKOUT" or TROUGH BOND BM BLOCK (TYPICAL UNIT EXCEPT AT ALL OPENINGS) SOLID BOT. BM. BM SHALL BE USED. PROVIDE GROUT STOP (RE.SPEC.) UNDER K.O. BOND BEAMS OVER CELLS WHICH ARE NOT TO BE REINFORCED AND GROUTED.

- REBAR POSITIONER OR SUPPORT @ 48" o.c.
- TOP REINF PER LINTEL NOTE #6 OF A/SI
- BOT REINF PER LINTEL NOTE #6 OF A/SI
- REINFORCING CHAIR SUPPORT @ 48" o.c.
- REBAR POSITIONER OR SUPPORT @ 48" o.c.
- TOP REINF PER LINTEL NOTE #4 OF A/SI
- BOT REINF PER LINTEL NOTE #6 OF A/SI
- REINFORCING CHAIR SUPPORT @ 48" o.c.
- REBAR POSITIONER OR SUPPORT @ 48" o.c.
- TOP REINF PER LINTEL NOTE #6 OF A/SI
- BOT REINF PER LINTEL NOTE #6 OF A/SI
- REINFORCING CHAIR SUPPORT @ 48" o.c.

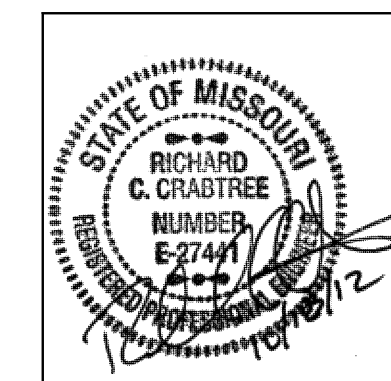

STRUCTURAL ENGINEER:  
**BOB D. CAMPBELL & CO.**  
4338 BELLEVUE  
KANSAS CITY, MISSOURI 64111  
TEL. (816) 531-4144  
FAX. (816) 531-8572

HISTORIC TRUMAN COURTHOUSE  
INTERIOR RENOVATION  
102 NORTH MAIN STREET, INDEPENDENCE, MISSOURI 64050

ISSUED FOR CONSTRUCTION

PROJECT NO.	
DATE	10-19-2012
DRAWN BY	CEJ
CHECKED BY	REC
REVISION	
DATE	
DESCRIPTION	

SHEET TITLE & NUMBER  
General Notes,  
Plans, and Details

COPYRIGHT © 2012  
PIPER-WIND ARCHITECTS, INC.

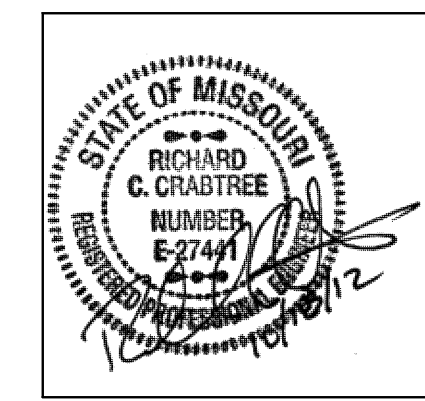

STRUCTURAL ENGINEER:  
**BOB D. CAMPBELL & CO.**  
 4338 BELLEVUE  
 KANSAS CITY, MISSOURI 64111  
 TEL. (816) 531-4144  
 FAX. (816) 531-8572

**HISTORIC TRUMAN COURTHOUSE**  
**INTERIOR RENOVATION**  
 102 NORTH MAIN STREET, INDEPENDENCE, MISSOURI 64050

ISSUED FOR CONSTRUCTION

PROJECT NO.	
DATE	10-19-2012
DRAWN BY	CEJ
CHECKED BY	RCB
REVISED BY	
REVISED DATE	DESCRIPTION

SHEET TITLE & NUMBER  
 Plans and Details

COPYRIGHT © 2012  
 PIPER-WIND ARCHITECTS, INC.

